



Model:KNPL-800

6Line Enterprise-class IP Phone

KNPL-800 is a high-end business IP phone, which is suitable for users who need flexibility and advanced functions, so that they can easily cope with the busy and complex work needs in their work. The KNPL-800's 7.2-inch main color display has 10 DSS keys. Used to set up BLF / fast dialing, multicast functions, etc. KNPL-800 is also equipped with high-definition voice, built-in Bluetooth, WIFI links, EHS support, Gigabit dual-port PoE, and IP camera.



HD audio, handset and speakerphone with support for wide-band audio

6 LINES

6 line keys with up to 4 SIP accounts, 8MPK extension keys with dual-color LED with 2 Left/Right keys



Dual LCD screens with digital BLF keys



Enterprise-level protection including secure boot, dual firmware images, and encrypted data storage



Integrated dual-band 802.11 a/b/g/n WiFi



Megabytes

Dual switched auto-sensing 10/100 Mbps Megabytes Ethernet ports with integrated PoE

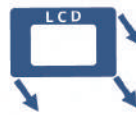

Swappable face plates to allow for easy logo customization



Integrated Bluetooth

KNPL-800 business class SIP phone

High-ranking phone function More efficient



6 SIP Line



High Digital



Bluetooth



10 DSS bottom



Inner Wifi



7.2-Inchs Colorful screen

The surface design is very elegant ,with touch screen and high resolution screen.

With the intelligent user interface it could be breakthrough surface and experiment.

Angle



50°

Function schedule (KNPL-800)

- *6 SIP Lines tripartite conference.
- *HD sound quality. (handset and speaker)
- *7.2-inches corlorful screen.
- *Megabytes Double Network Port,POE is optional funtion.
- *Inner Bluetooth function.
- *Connectible Wifi. (Wi-fi Dongle)
- *Surport EHS earphone.
- *H.264 Video Decoding for Video Telephone.
- *Surport mainstream IP PBX/softswitch/IMS Platform.
- 3CX, Asterisk, Broadsoft,Elastix,Avaya.



Protocols/Standards	SIP RFC3261, TCP/IP/UDP, RTP/RTCP, HTTP/HTTPS, ARP, ICMP, DNS(A record,SRV,NAPTR), DHCP, PPPoE, TELNET, TFTP, NTP, STUN, SIMPLE, LLDAP, LDAP, TR-069, 802.1x, TLS, IPV4.
Network Interfaces	Dual switched auto-sensing 10/100 Mbps Megabytes Ethernet ports with integrated PoE.
Graphic Display	7.2 inch.
HD Audio	Yes,HD handset and speakerphone with support for wideband audio.
DSS Key	10 DSS key on 7.2 inch screen.
Voice Codecs and Capabilities	Support for G7.29A / B, G.711μ/ a-law, G.726, G723, i n-band and out-of-band DTMF (i n audio, RFC2833) , SIP INFO) .
Feature Keys	6line keys with up to 6SIP accounts, , 8MPK extension keys with dual-color LED with 2Left/Right keys, , 4XML programmable context sensitive softkeys, 5navigation/menu keys , 11dedicated, for: MESSAGE (with LED indication), phonebook,transfer,conference,hold,handset,mute,send/redial,speakerphone,vol+,vol-
Base stand	Base support
Telephone Feature	Hold, transfer, forward, call park, call pickup, downloadable phonebook(XML,LDAP, up to 2000 items), call waiting, call log(up to 2000 records), off-hook auto dial, auto answer, flexible dial plan, hot-desking, personalized music ringtones and music.on hold, server redundancy and fail-over
QoS	Layer 2 QoS (802.1Q, 802.1P) and Layer 3 (ToS, DiffServ, MPLS) QoS
Multi-language	English, German, Italian, French, Spanish, Portuguese, Russian, Croatian, Chinese,Korean, Japanese etc.
Security	User and administrator level passwords, MD5 and MD5-sess based authentication, TLS, 802.1x media access control, secure boot
Upgrade/Provisioning	Firmware upgrade via FTP/TFTP / HTTP / HTTPS/TR-069, mass provisioning .
Temperature and Humidity	Operation: 0°C to 40°C, Storage: -10°C to 60°C Humidity: 10% to 90% Non-condensing
Power & Green Energy Efficiency	Universal power adapter included - Input:100-240V ; Output: +12V, 1.5A ; IntegratedPower-over-Ethernet(802.3af), Max power consumption 3.5W(power adapter) or 4W(PoE)
Package Content	KNPL-800 phone, handset with cord, phone stand, 12V power adapter, network cable, Quick Installation Guide.
Physical	Unit weight: 950g ; Package weight: 1460g Dimension: 234mm x 213mm x 82.2mm
800 characteristic	10 DSS keys two colorful screen
Compliance	CE: EN 55032; EN 55035; EN 61000-3-2; EN 61000-3-3; EN 60950-1; EN 301489-1; EN 301489-17; EN 300328; EN 301893; EN 62311RCM: AS/NZS CISPR32; AS/NZS 61000.3.2; AS/NZS 61000.3.3; AS/NZS 4268; AS/NZS 60950.1; AS/CA S004 12V power adapter

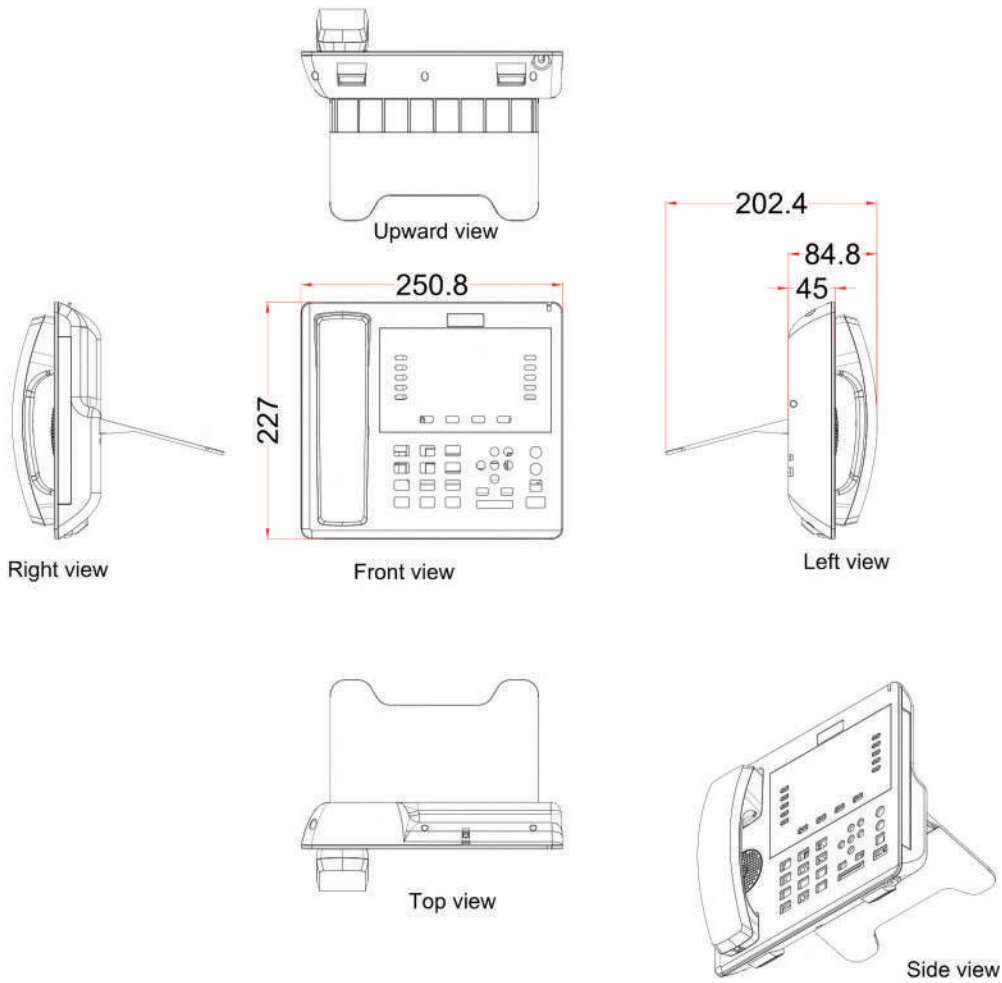

投影关系 Projective relation 	产品名称: KNPL-800总装图 Item Name: *		KNTECH 深圳市西骏科技有限公司 昆仑科技 HK KOON Technology Ltd	
未注角度与线性尺寸公差按 GB/T 1804-m Unspecified angle and linear dimension common difference according to GB/T 1804-m	产品型号: Product model: KNPL-800		主板型号: * PCB model: *	
	结构图号: * Artwork Number: *		防水等级: * IP Rating: *	
材料: * Material: *	批准: * Ratifier: *	日期: * Date: *	表面处理: * Surface treatment: *	
毛刺面: 内侧 Burr side: BURRSIDE	审核: * Checked by: *	日期: * Date: *		
单位: mm Measure unit: mm	比例: 1:1 Scaling: 1:1	绘图: * Drawn by: *	日期: * Date: *	页数: 页数 Paginal number: 页数 版本: 版本 Version: 版本